

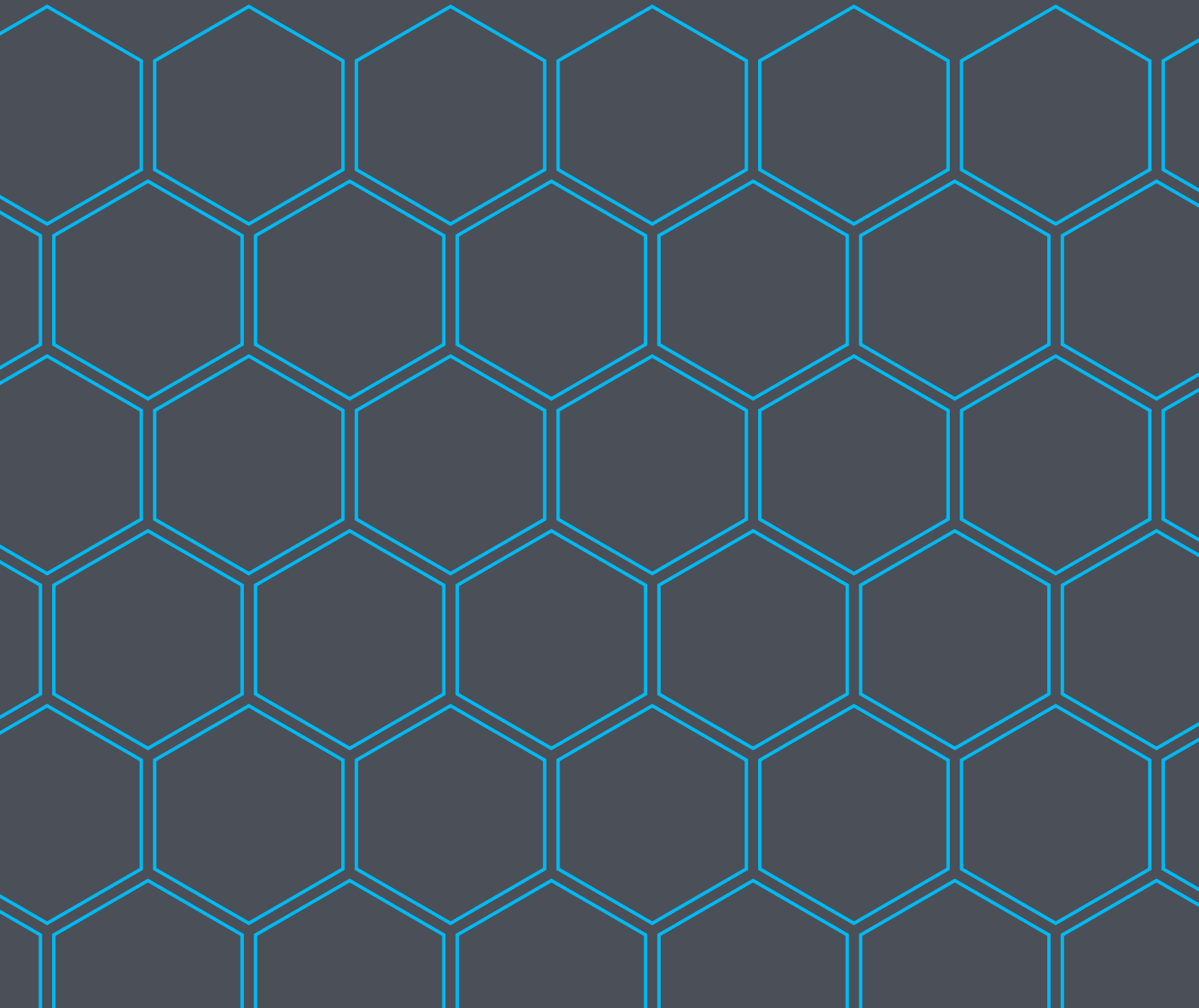

**TIMOLEON EUROPE**

---

# **OEM TIMOLEON MANUFACTURING EUROPE PRODUCT RANGE**



## UNITED KINGDOM



Craig Parker  
Managing Director  
UK and Europe  
T +44 (0) 1392 44 93 64  
M +44 (0) 7552 161 298  
E [craig.parker@timoleon.eu.com](mailto:craig.parker@timoleon.eu.com)

Melrose House  
Pynes Hill  
Exeter  
Devon  
EX2 5AZ

[timoleon.eu.com](http://timoleon.eu.com)

## POLAND



Craig Sayers  
Director - Operations  
Europe  
T +48 862166257  
M +48 507403195  
E [craig.sayers@timoleon.eu.com](mailto:craig.sayers@timoleon.eu.com)

Szkolna 2A/1  
Lomza  
18-400  
Polska

# CONTENTS

<b>TIMOLEON .....</b>	<b>5</b>
<b>WHO WE ARE .....</b>	<b>5</b>
<b>OUR BUSINESS &amp; EXPERTISE.....</b>	<b>5</b>
<b>YEARS OF EXPERIENCE.....</b>	<b>5</b>
<b>PANEL DESIGN .....</b>	<b>7</b>
<b>CHOICES &amp; OPTIONS .....</b>	<b>9</b>
<b>CONSTRUCTIONS.....</b>	<b>9</b>
<b>MANUFACTURE.....</b>	<b>11</b>
<b>PROCESS.....</b>	<b>13</b>
<b>WORKING WITH US.....</b>	<b>13</b>
<b>STANDARD PRODUCTS.....</b>	<b>14</b>
<b>ROUTED &amp; STRIP FOILED CHIPBOARD PANEL .....</b>	<b>15</b>
<b>LOW BUILD UP ROUTED INSULATION PANEL FOR THIN SCREEDS .....</b>	<b>16</b>
<b>ROUTED &amp; LINED INSULATION PANEL.....</b>	<b>17</b>
<b>ROUTED INSULATION PANEL FOR DIFFUSER PLATES.....</b>	<b>18</b>
<b>MDF BASED PANEL .....</b>	<b>19</b>
<b>ROUTED CEMENT FACED INSULATION PANEL.....</b>	<b>20</b>
<b>PANEL DESIGNS.....</b>	<b>21</b>



**Only working with industry leading companies to provide the products they need for their customers to offer a first class underfloor heating installation.**

## **TIMOLEON**

### **WHO WE ARE**

Established in 2008. Timoleon combines the best in technical knowledge and understanding of the underfloor heating and cooling industry. As a manufacturer and designer, Timoleon has developed and pioneered a variety of different emitter products.

### **OUR BUSINESS & EXPERTISE**

Underfloor heating is now a well-established technology. The benefits are well known such as lower running costs, being more comfortable, providing design freedom, using less energy and being safer.

At Timoleon we see these technologies transforming the indoor environment. Products that we make for timber and dry constructions for example, have pushed the industry even further forward and generated invaluable experience in good emitter design.

We manufacture products to work with all floor constructions using a variety of materials, pipe centres & sizes.

### **YEARS OF EXPERIENCE**

At Timoleon, we can draw on years of combined experience in the underfloor heating industry, and have the capability to deliver systems for the most challenging of installations.

Expertise + buying volume + specialised manufacturing process = lowest price



**Our work with you is confidential - your unique design requirements always remain your intellectual property.**

## **PANEL DESIGN**

Product research and development is the basis on which our company has been built. With a commitment to continuous product development, we make sure that we are always at the forefront of our industry. We take great pride in delivering the highest quality products that always meet our customers needs.

The range of products and design knowledge available from Timoleon with regard to dry systems is unprecedented. Timoleon has undergone more independent testing of emitters than any other underfloor heating manufacturer and is able to provide this service for any new products that it manufactures.

We take care of the whole process, from understanding your requirements, through to design, manufacture and supply.

We dedicate an experienced Business Development Manager to look after every aspect of a project, from understanding your requirements through to specification, manufacture, delivery and beyond.

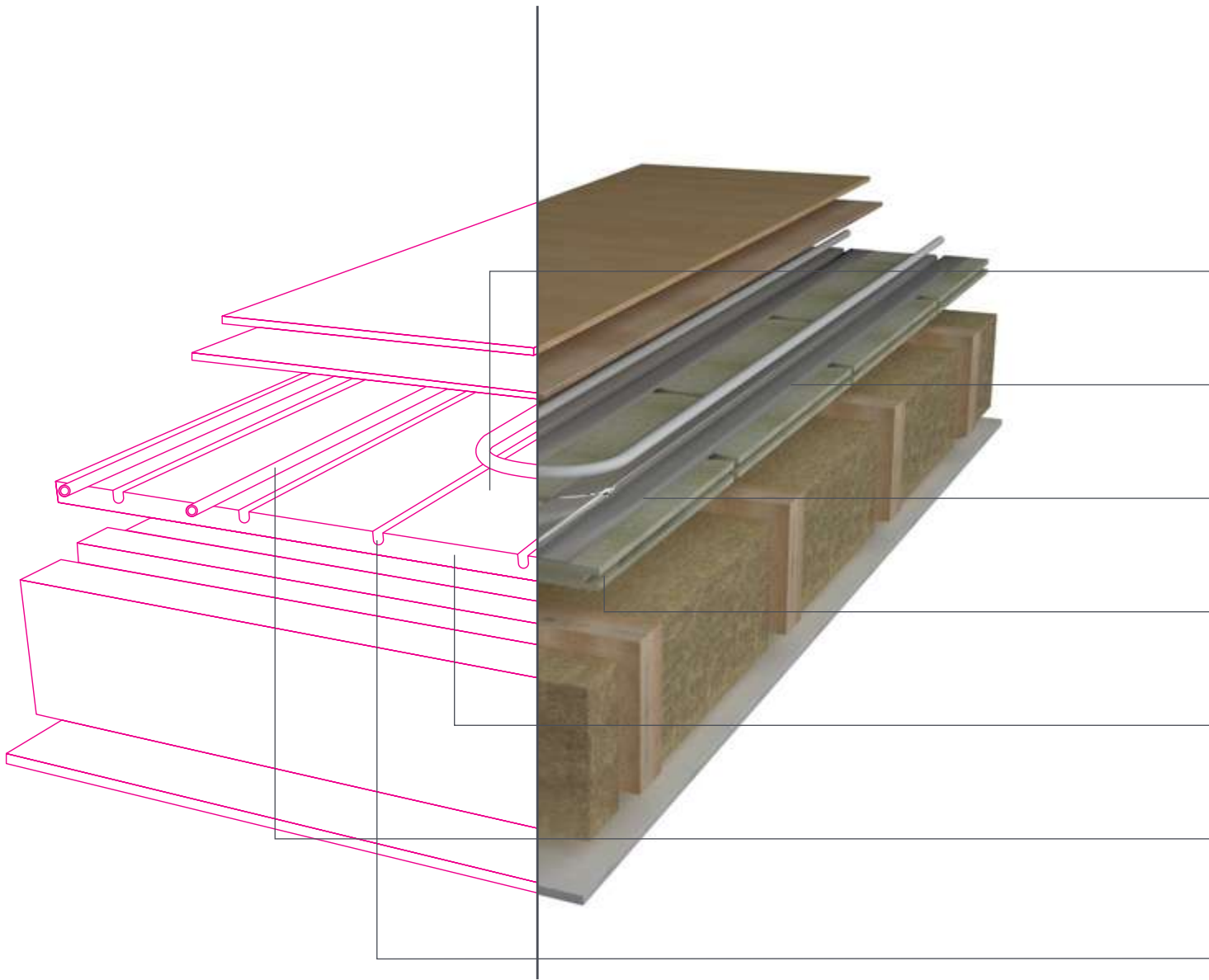



## CHOICES & OPTIONS

A wide variety of choice is available to suit any construction or application. Timoleon can easily create new designs from scratch or adopt an existing emitter model.



### STANDARD OR BESPOKE DESIGN

Channel design that enables the installation to be done more easily.



### DIFFUSER THICKNESS & TYPE

Bonded soft temper aluminium with thickness from 50 micron ( $\mu\text{m}$ ) or unfoiled for diffuser plates.



### BRANDING



### PANEL THICKNESS

As required but typically from 15mm upwards.



### MATERIALS

Expanded polystyrene, extruded polystyrene, wood fibre, wood chip, cementboard and more.



### PIPE SIZE

From 10mm+.



### PIPE CENTRES

As required.

## CONSTRUCTIONS

Panels can be designed to suit any floor construction. Our unique technical skills and manufacturing knowledge will always ensure that the product delivers the optimum performance for the given application.



# Our manufacturing process enables products to be created that can be incorporated within all types of floor, wall or ceiling construction.

## MANUFACTURE

Timoleon's manufacturing process enables products to be created that can be incorporated within all types of floor, wall or ceiling construction. Our unique ability, with patented manufacturing techniques, enables us to bespoke products manufacturing from a diverse range of materials allowing underfloor heating to be a consideration in any floor construction.

For example, Timoleon manufactures a range of insulation based floating floor systems that can be manufactured from extruded polystyrene (XPS) for applications where high-compressive strength is important or from (EPS) where a lower cost expanded polystyrene system is more appropriate. As with all Timoleon systems the product can be made to use any size or type of pipe and in a range of thicknesses.

Low build up systems enable underfloor heating to be used in retrofit applications where the existing floor cannot be replaced. These systems rely on being easy to install with installation over the existing floor and being as thin as possible. Timoleon has many years experience in the manufacture of these products using materials including cementitious board and wood fibre.

Timoleon is also able to integrate acoustic insulation into its products for applications where sound-reduction is important.

Structural floors with underfloor heating can be complicated to manufacture, Timoleon has long experience manufacturing panels from chipboard, plywood, OSB and other materials in a variety of sizes. Ensuring structural performance and conforming with the appropriate standards is crucial but often overlooked in the industry. Timoleon rigorously tests all of its structural floors to ensure that they comply.

**Timoleon are market leaders in innovative dry construction products for both solid and suspended floor types with considerable market experience, patented products and unique technology.**

**Timoleon is able to manufacture products to suit our customer's needs whatever the application.**

## PROCESS

### 1. SPECIFICATION

Client decides on the product specification whether standard or bespoke.

### 2. SIGN OFF ON BESPOKE PRODUCT

Samples are manufactured for the client, revisions made if necessary and then signed off.

### 3. TESTING

If testing is required, for example to determine the heat output, then Timoleon can undertake this on the client's behalf.

### 4. MANUFACTURE AND DELIVERY

Supplying direct to the client or to site.

## WORKING WITH US

If you have an application for heating and cooling emitter technologies we can work with you to manufacture the right product for your individual requirements. Timoleon can provide quotes for existing product designs, where there is no infringement on intellectual property, or to alter and bespoke an existing product to suit your specific application.

All our customers work with a dedicated Business Development Manager throughout this process. We will provide CAD designs and samples for sign off including any branding that may be required. As part of the supply, Timoleon is able to provide isometrics and illustrations for inclusion in your technical and sales literature.

Timoleon has a wide range of generic installation instructions, these are available to be adapted to suit your application.

For standard products we are able to provide kWh values so that heat output can be calculated to EN1264 standards.

### NOTE

We are currently looking to add to our Standard range in the near future, with testing underway. These products include routed chipboard, hybrid boards, routed cement boards and acoustic solutions amongst others.

Look out for these on our website and/or register for interest [timoleon.eu.com](http://timoleon.eu.com)



**STANDARD PRODUCTS**

## ROUTED & STRIP FOILED CHIPBOARD PANEL



Combination Panel (Pattern 6)

CB12-PO6-G5  
CB12-PO6-G6  
CB12-PO6-G7

### EXAMPLE CROSS SECTION (CB12)

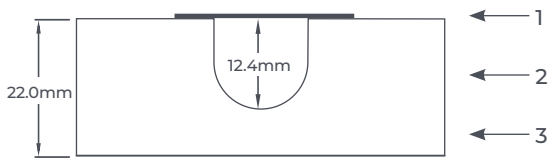

- 1 – Soft temper aluminium diffuser
- 2 – 12mm channel
- 3 – P5, P6 or P7 chipboard

Panel dimensions            2400 x 600mm

### APPLICATION CROSS SECTION

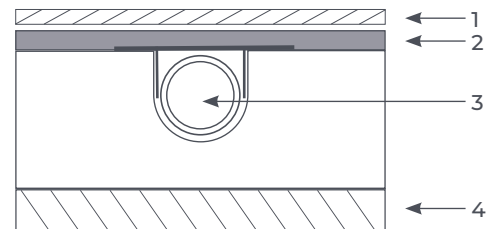

- 1 – Floor finish
- 2 – Minimum 6mm flooring grade plywood
- 3 – 12mm pipe
- 4 – Joisted or battened subfloor

### PRODUCT OVERVIEW

Independently tested structural underfloor heating panel which replaces the floor deck used in constructions on a joisted or battened floor and provides a high output as the pipe is as close to the floor finish as possible. Manufactured from P5, P6 or P7 tongued and grooved chipboard, the panels have pre-routed channels to accept 12mm continuous pipe (supplied by others) and are factory fitted with aluminium diffuser strips to provide improved performance and a means of detecting the pipe. The panels are laid on joists or battens in industry standard brick pattern and the pipe is installed by piercing through the soft temper aluminium diffuser strips. The flow and return pipework for each circuit drop into the joist space and are fed to and from the manifold as a continuous system beneath the floor level. The panels then require a minimum 6mm flooring grade Ply screwed and glued to complete the structural deck.

### PRODUCT OPTIONS

Product	Panel thickness	Pipe channels diameter	Pipe centres	Grade of chipboard	Panel patterns
CB12	22mm	12mm	150mm	G5	PAT6-Grade P5
CB12	22mm	12mm	150mm	G6	PAT6-Grade P6
CB12	22mm	12mm	150mm	G7	PAT6-Grade P7

## LOW BUILD UP ROUTED INSULATION PANEL FOR THIN SCREEDS



Combination Panel (Pattern 7)

Combination Panel (Pattern 8)

### EXAMPLE CROSS SECTION (LS12)

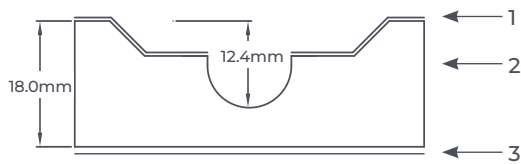

- 1 – Primer
- 2 – 300kPa XPS insulation
- 3 – Peel off paper gel with high tack gel adhesive

Panel dimensions            1200 x 600mm

### APPLICATION CROSS SECTION

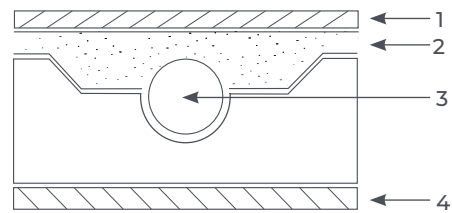

- 1 – Floor finish
- 2 – Levelling compound
- 3 – 12mm pipe (LS12)
- 4 – Sub floor

### PRODUCT OVERVIEW

High grade XPS insulation with peel off adhesive backing and a pre primed top surface. Suitable for laying over both flat and level primed concrete/screed or timber floors in new build or retro fit. The panel features pipe channels and diffuser channels to enhance the output. The product is finished with a thin levelling compound to receive your chosen floor finish (8–12mm).

### PRODUCT OPTIONS

Product	Panel thickness	Pipe channels diameter	Pipe centres	Compressive strength	Thermal conductivity	Panel patterns
LS12	18mm	12mm	150mm	300kPa	0.034 W/mK	P7
LS14	18mm	14mm	150mm	300kPa	0.034 W/mK	P7
LS16	25mm	16mm	150mm	300kPa	0.034 W/mK	P8



## ROUTED & LINED INSULATION PANEL

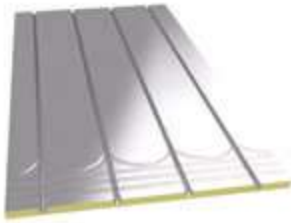

Combination Panel (Pattern 1)



Combination Panel (Pattern 2)

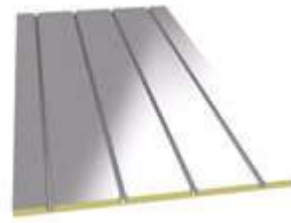

Straights Panel (Pattern 3)

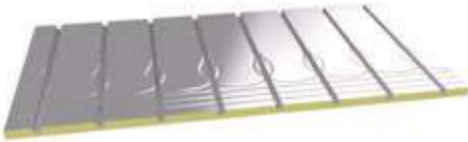

Loop with Flow and Return Channels Panel (Pattern 4)

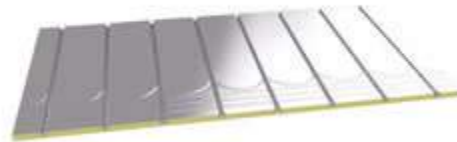

Loop with Flow and Return Channels Panel (Pattern 5)

### EXAMPLE CROSS SECTION (FF12)

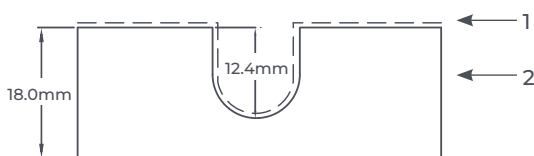

- 1 – Soft temper aluminium fully lined channel (100µm)
- 2 – 300kPa XPS insulation

### APPLICATION CROSS SECTION

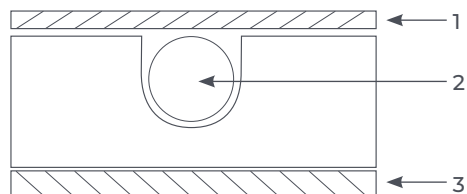

- 1 – Floor deck/finish
- 2 – 12mm pipe (FF12)
- 3 – Sub floor

Panel dimensions 1200 x 600mm

## PRODUCT OVERVIEW

High grade XPS insulation for fully floating floors to support an overlaid tongue and groove or timber floor deck above. The panel features a pre-bonded soft temper aluminium heat diffuser with fully lined straight channels. This panel can be floated, bonded or even mechanically fixed to a solid or timber substructure.

## PRODUCT OPTIONS

Product	Panel thickness	Pipe channels diameter	Pipe centres	Compressive strength	Foil diffuser	Thermal conductivity	Panel patterns
FF12	18mm	12mm	150mm	300kPa	100µm	0.034 W/mK	P1 or P3 + P5
FF14	18mm	14mm	150mm	300kPa	100µm	0.034 W/mK	P1 or P3 + P5
FF16	25mm	16mm	150mm	300kPa	100µm	0.034 W/mK	P2 or P3 + P4

## ROUTED INSULATION PANEL FOR DIFFUSER PLATES



Combination Panel (Pattern 2)



Straights Panel (Pattern 3)



Loop with Flow and Return Channels Panel (Pattern 4)

### EXAMPLE CROSS SECTION (PF16)

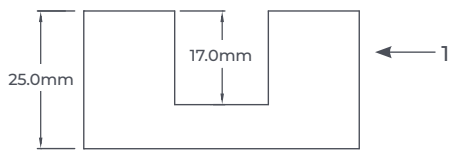

1 – 300kPa XPS insulation

### APPLICATION CROSS SECTION

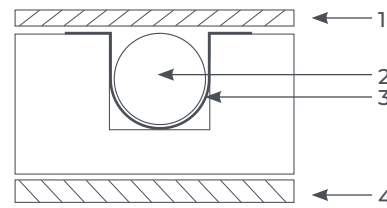

- 1 – Floor deck/finish
- 2 – 16mm pipe (PF16)
- 3 – Diffuser plate
- 4 – Sub floor

Panel dimensions      1200 x 600mm

### PRODUCT OVERVIEW

High grade XPS insulation panel featuring 17mm square edge channels, specifically for use with Diffuser Plates utilising 16mm pipe at 150mm centres. The panels can be floated, bonded or mechanically fixed to solid or timber subfloors.

### PRODUCT OPTIONS

Product	Panel thickness	For use with diffuser plates		Compressive strength	Thermal conductivity	Panel patterns
		Pipe channels diameter	Pipe centres			
PF16	25mm	16mm	150mm	300kPa	0.034 W/mK	P2 or P3 + P4

## MDF BASED PANEL

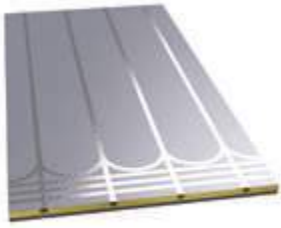

Combination Panel (Pattern 1)

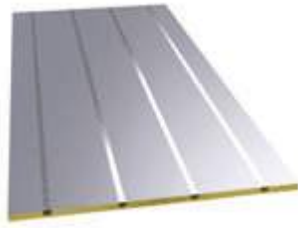

Straights Panel (Pattern 3)

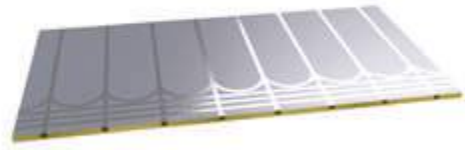

Loop with Flow and Return Channels Panel (Pattern 5)

### EXAMPLE CROSS SECTION (WF12)

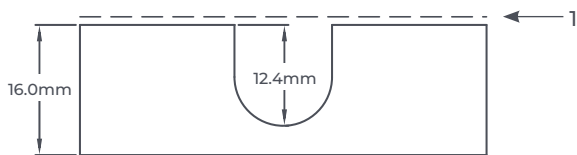

1 – Soft temper aluminium (100µm)

Panel dimensions 1200 x 600mm

### APPLICATION CROSS SECTION

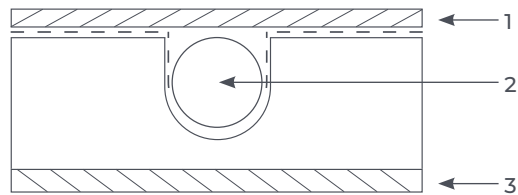

1 – Floor deck/finish

2 – 12mm pipe (WF12)

3 – Sub floor

## PRODUCT OVERVIEW

Low build up MDF panels designed for use with a covering layer such as 6mm ply for carpet or a laminate or wood floor as the finish. Panels can be floated/bonded or mechanically fixed to solid or timber subfloors.

## PRODUCT OPTIONS

Product	Panel thickness	Pipe channels diameter	Pipe centres	Foil diffuser	Thermal conductivity	Panel patterns
WF12	16mm	12mm	150mm	100 µm	0.13 W/mK	P1 or P3 + P5
WF14	18mm	14mm	150mm	100 µm	0.13 W/mK	P1 or P3 + P5

## ROUTED CEMENT FACED INSULATION PANEL



Combination Panel (Pattern 1)



Straights Panel (Pattern 3)



Loop with Flow and Return Channels Panel (Pattern 5)

### EXAMPLE CROSS SECTION (TB12)

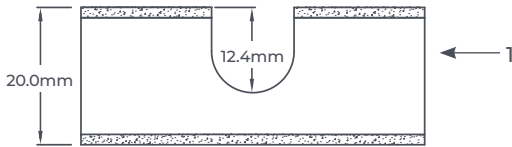

1 – 20mm Cement Faced XPS insulation

Panel dimensions 1200 x 600mm

### APPLICATION CROSS SECTION

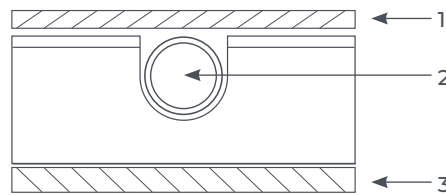

1 – Tile adhesive and finish

2 – 12mm pipe (TB12)

3 – Sub floor

### PRODUCT OVERVIEW

High density XPS insulated panel faced on both sides with a fibre mesh and cement. Suitable for adhering or mechanically fixing over both flat and even solid or timber floors. Ideal for tiling directly to the top surface using the correct adhesive for the type of tile. As the tiles and adhesive are conductive the heat output and warm-up are sufficient and a aluminium diffuser is not required.

### PRODUCT OPTIONS

Product	Panel thickness	Pipe channels diameter	Pipe centres	Compressive strength	Thermal conductivity	Panel patterns
TB12	20mm	12mm	150mm	250 Kpa	0.034 W/mK	P1 or P3 + P5

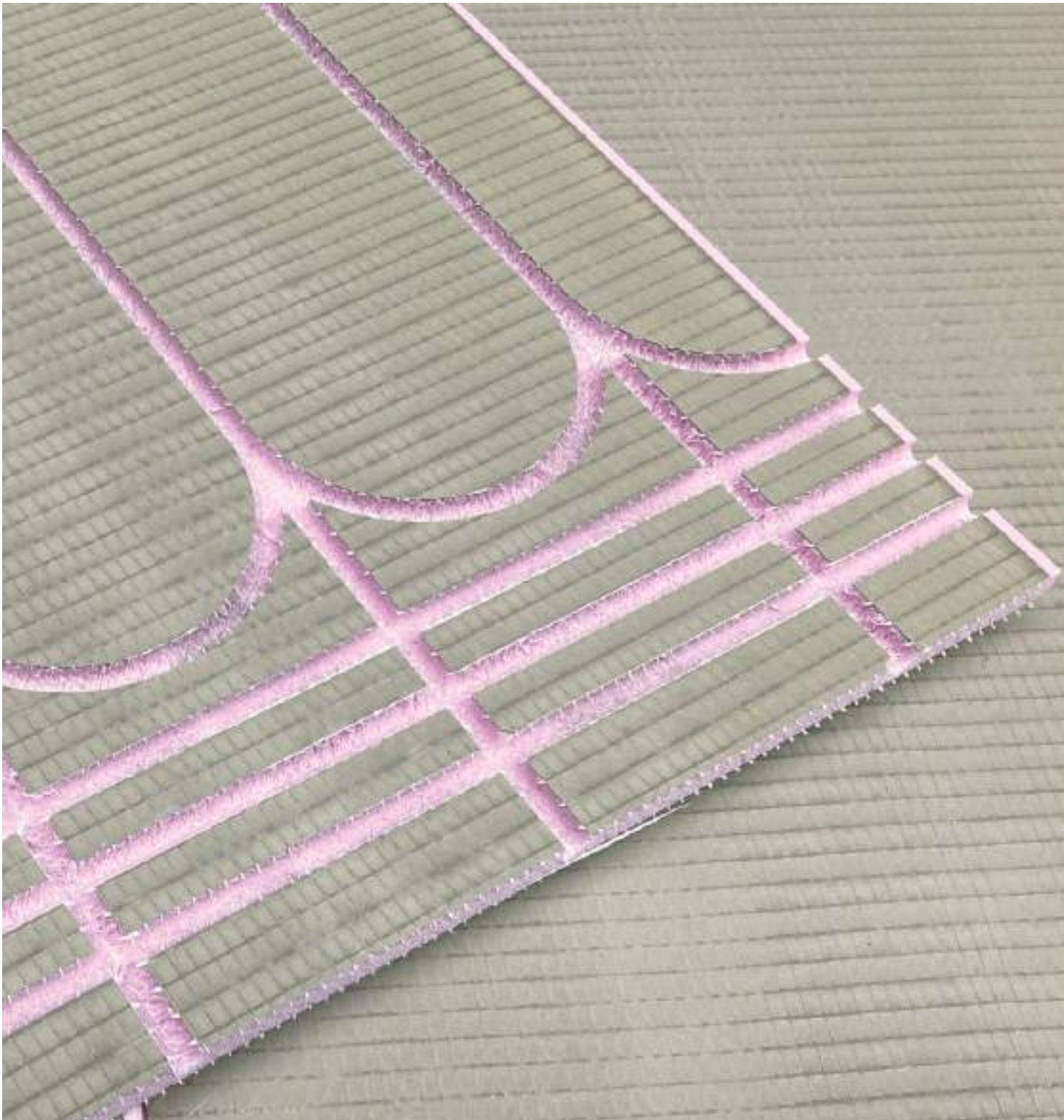

**PANEL DESIGNS**

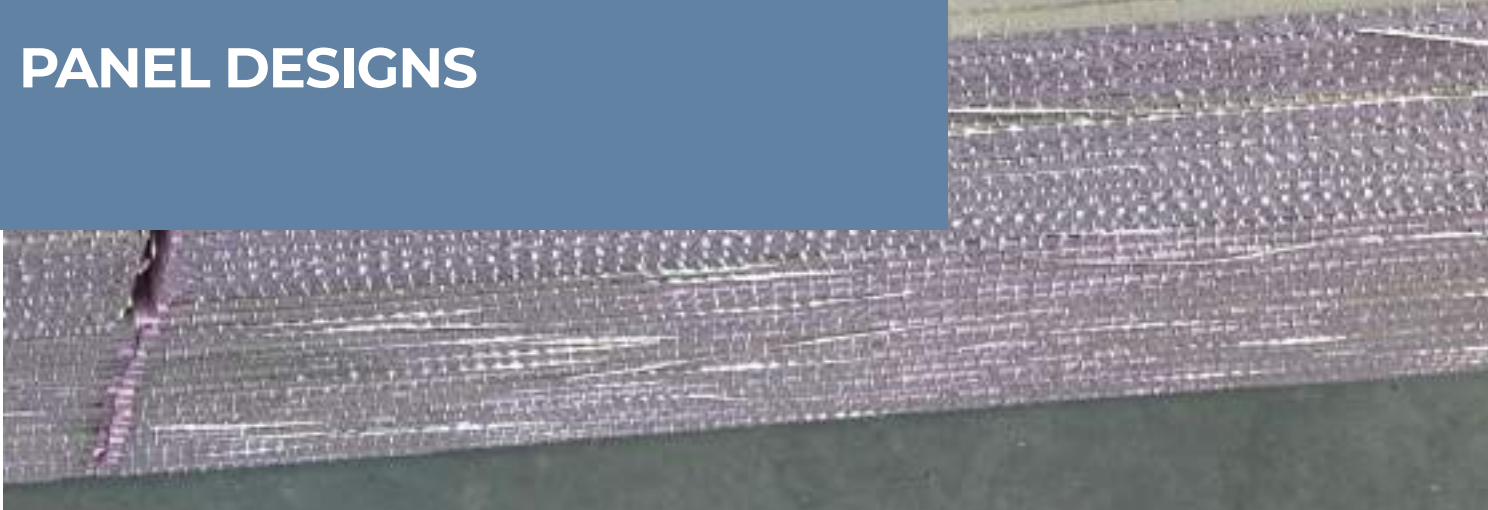

# PANEL DESIGNS

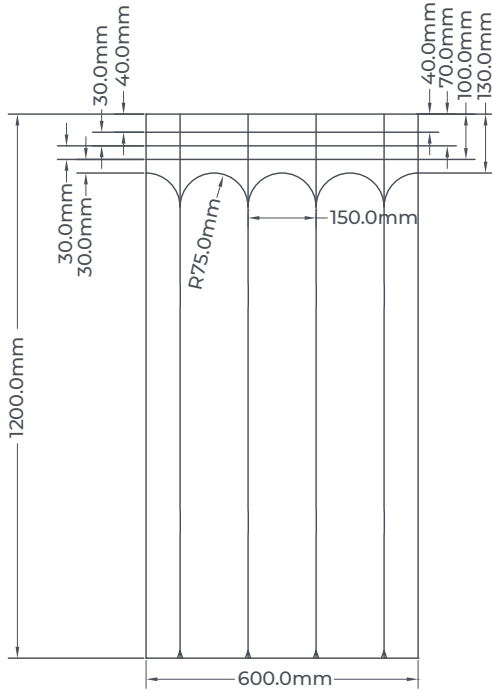

Combination Panel (Pattern 1)

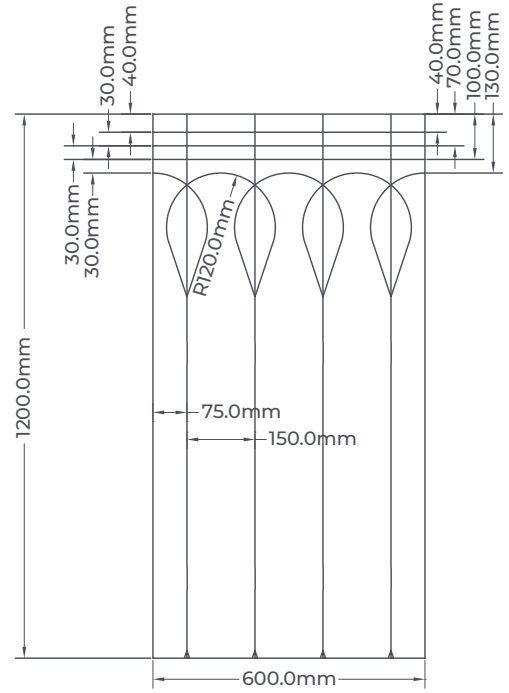

Combination Panel (Pattern 2)

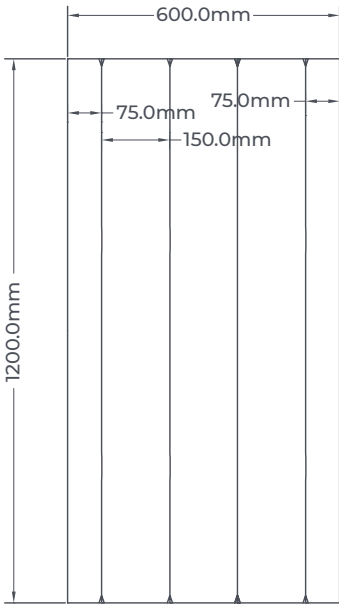

Straights Panel (Pattern 3)

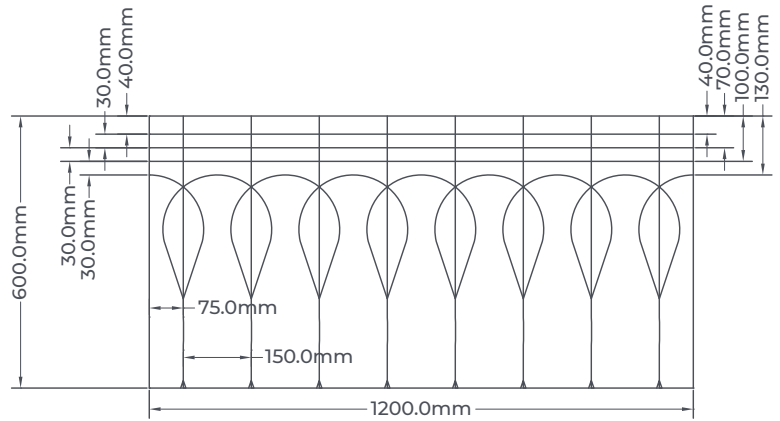

Loop with Flow and Return Channels Panel (Pattern 4)

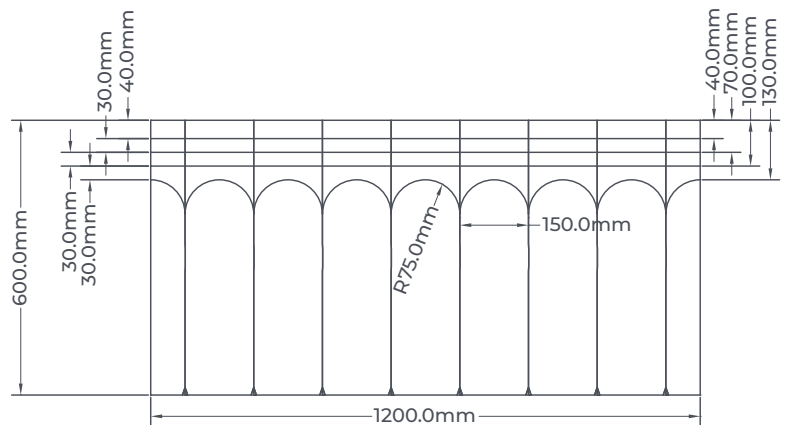

Loop with Flow and Return Channels Panel (Pattern 5)

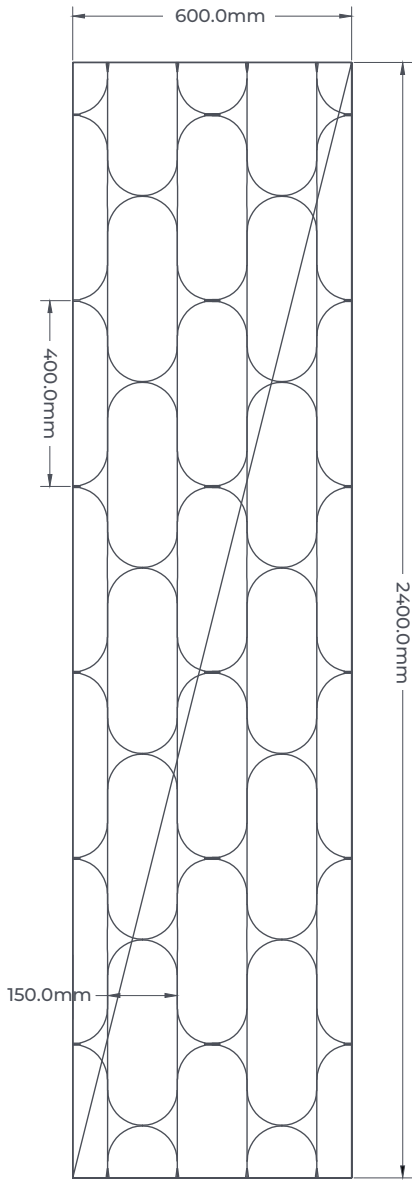

Combination Panel (Pattern 6)

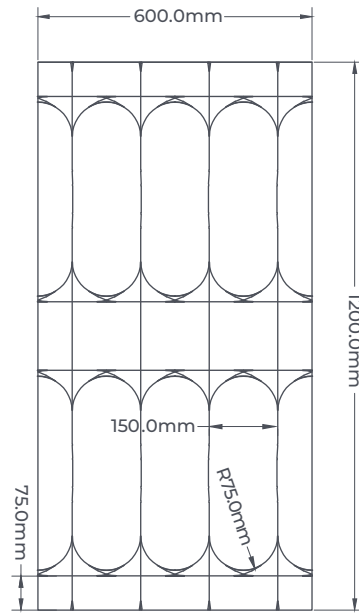

Combination Panel (Pattern 7)

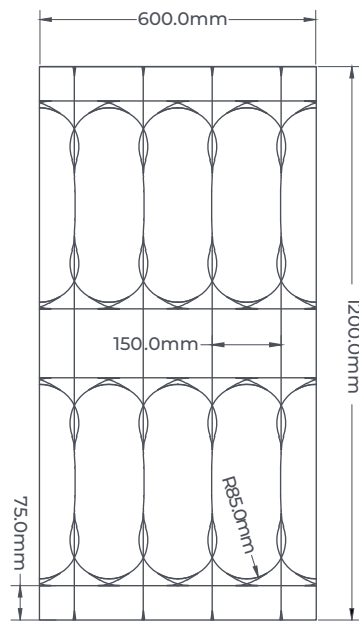

Combination Panel (Pattern 8)

© Timoleon Sp.z o.o 2022  
All information correct at time of going to print. Timoleon Sp.z o.o reserves the right to change or alter information contained within this brochure without prior notice.  
All images are © Timoleon Sp.z o.o. All rights reserved. Timoleon Sp.z o.o, Szkolna 2A/1, Lomza, 18-400, Polska.

REF: TEU1/22

