

LS16

DATASHEET – LOW BUILD UP ROUTED INSULATION PANEL FOR THIN SCREEDS

DS_LS16_02.0

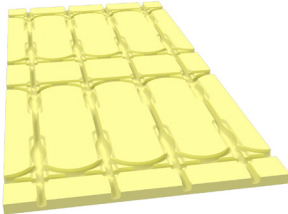

Combination Panel (Pattern 9)
LS16-PO9

ROUTED PANEL CROSS SECTION

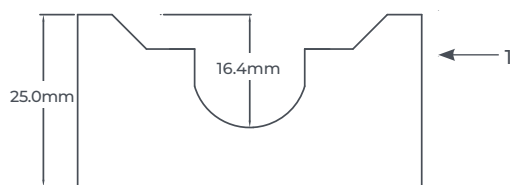

1 – 300kPa XPS insulation

APPLICATION CROSS SECTION

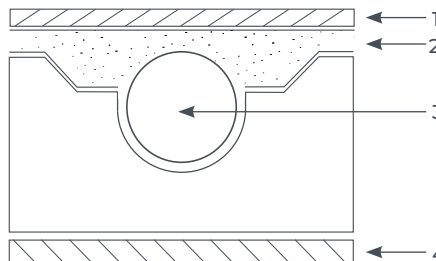

1 – Floor finish
2 – Levelling compound
3 – 16mm pipe
4 – Sub floor

PRODUCT OVERVIEW

High grade XPS insulation routed with pipe channels and diffuser channels to enhance the output. The product is bonded to a flat and level primed concrete/screed or timber floor in new build or retrofits. The product is finished by priming the top of the panel before a thin leveling compound is applied to receive your chosen floor finish (8-12mm).

PRODUCT TECHNICAL DATA

Material	XPS Extruded Insulation
Compressive Strength (EN 826)	300kPa
Panel dimensions	1200 x 600mm
Thickness	25mm
Panel options	Combination panel (P9)
Pipe channels/external pipe diameter	16mm
Panel finish	Routed pipe and diffuser channels

Insulation properties

Regularity (EN 824)	≤ 5
Creep with compression 2% reduction, 1.5% deformation over 50 years (EN 1606)	90kPa
Modules of compressive elasticity (EN 826)	15000kPa
Bulk Density (EN 1607)	32kg/m ³
Nominal thermal conductivity (EN 13164)	0.034 W/mK
Application Temperature Range	-150 to +75°C
Fire Behaviour (EN 1305-1)	E
Water absorption on long immersion (EN 12087)	≤ 1.0% vol.
Thermal Expansion Coefficient	0.07mm/(mK)

MATERIAL CREDENTIALS

- 100% recyclable.
- Raw material manufactured in accordance with EN 13164.
- No CFC, HCFC or HFC gases or fire retardants that contain hazardous bromine compounds are used in the manufacturing of the insulation. Neither do any gases, particles or fibres that are hazardous to health evaporate or release from the insulation. Rated M1 for emissions, i.e. the best indoor air quality.

INSTALLATION GUIDANCE

1. Store panels in a safe dry, weather tight area out of direct sunlight.
2. Ensure that the subfloor is level and free from dust & debris (best practice to use a primer and to refer to the floor finish manufacturers' instructions which should always take precedence).
3. Prime the underside of the LS16 panel and bond to the subfloor with a sulfate adhesive.
4. Once laid use walking boards to protect the panels, especially in areas of high-level foot traffic.
5. Prime the top of the panel and install pipework following your installation drawing.
6. Pressure test the system.

DETAILS OF PANEL DESIGN

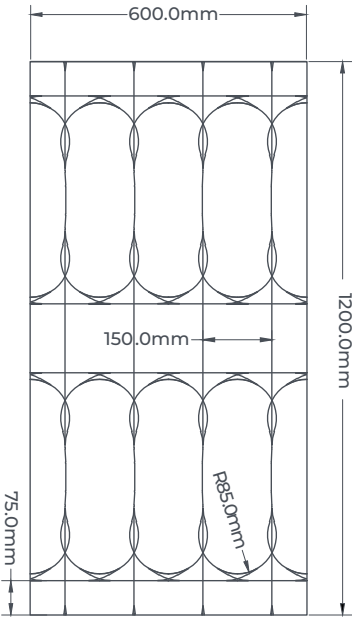

Combination Panel (Pattern 9)

PRODUCT TOLERANCE	
Panel	
Length	+/-2mm
Width	+/-2mm
Thickness	+/-0.5mm
Channel routed depth	
16mm pipe	-0/+0.5mm